

EVO Home Lifts

International House
Southampton International Business Park
George Curl Way, Southampton
SO18 2RZ

t. 020 3195 3958

e. sales@evohomelifts.co.uk

www.evohomelifts.co.uk



The Vitesse

Capable, Sophisticated, Spacious

With a design large enough to carry multiple passengers between floors, the Vitesse uses a minimum of floor space in your home, whilst expanding on the already rich functionality of the Evo Home Lift range.

About the Vitesse

Our Vitesse builds upon over 40 years of experience in market leading homelift design and innovation.

Stylishly designed for two or more persons, the Vitesse requires no major building works, and takes as little as a few days to install.

The exterior aesthetic of the lift is characterized by two, striking see-through panels on either side, and panoramic glazing on the lift door. The extensive glazing makes the already spacious interior of the Vitesse appear seamless with the rest of the room.



The Main Benefits of the Vitesse

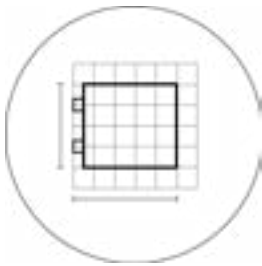

Space Saving Design

The Vitesse design uses a minimum of space in your home.



Easy to Install

Requiring no major building work, fitting the lift can take as little as a few days!



Keep your staircase free

Unlike stairlifts, the Vitesse can be placed practically anywhere in your home.



Technical Details

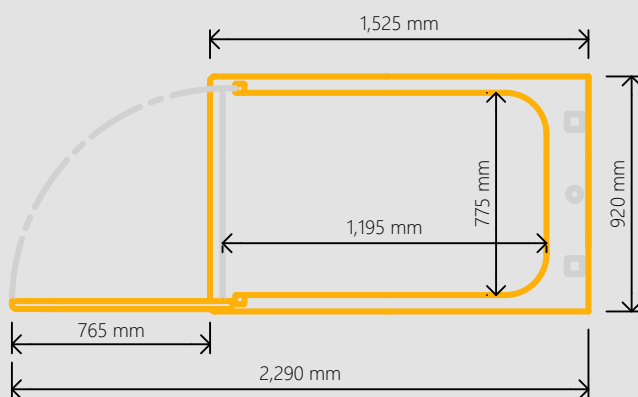

Maximum Load	250 kg
Maximum Travel	3,500 mm
Usable Platform Dimensions	755 x 1,195 mm
Lift Footprint	920 x 1,525 mm
Minimum First Floor	2,180 mm < 3 m 2,315 mm > 3 m